

BLOCK BUDDY™

ASSEMBLY INSTRUCTIONS

*We welcome you to the family of quality Demand EIFS Products.
You have purchased one of the finest heavy duty foam cutting machines available.
Call today for our current catalog and/or fastener spec catalog.*



DEMAND PRODUCTS, INC.

1055 Nine North Drive
Alpharetta, Georgia 30004 USA
1-800-325-7540

BLOCK BUDDY™

ASSEMBLY INSTRUCTIONS

1.

Open the shipping carton. Remove all the parts. You will find the harp and table are 2 separate parts. The attachment knobs are attached to the bottom side of the table.

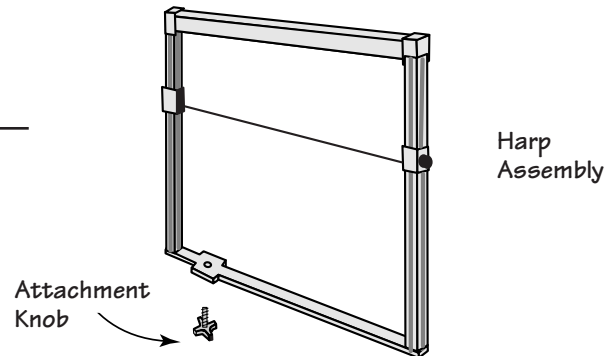

2.

Fold the legs out on the table unit and secure the legs.

Remove the locking bar on the front bottom of the table.

Place the legs on the right side of the table through the harp and secure the harp with the attachment knob.

Replace the Locking Bar Assembly.

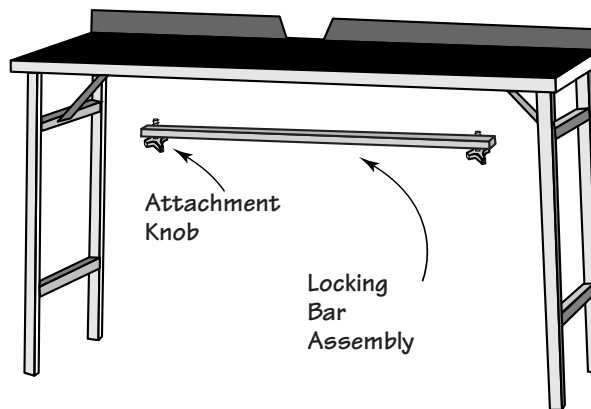

3.

To replace the Ni-Chrome wire. Place the Ni-Chrome wire onto the left travel hook and tightly wrap. Run enough Ni-Chrome wire over to the right spring and travel hook and pull the wire tight enough so that the spring will stretch open about 1 to 1½". Ideally, you want the spring stretched to 2 times its normal length. Now wrap the Ni-Chrome wire around itself in a tight wrap knot.

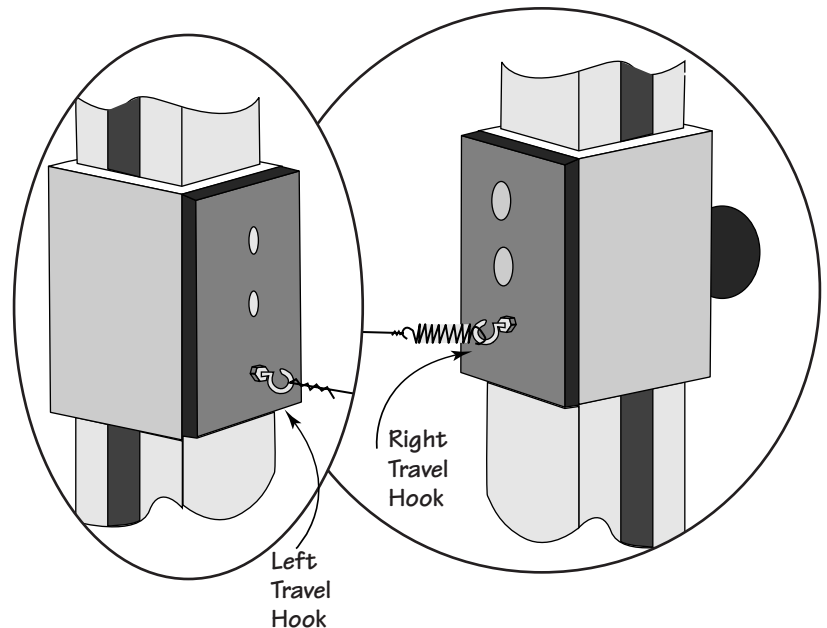

DEMAND PRODUCTS, INC.

1055 Nine North Drive
Alpharetta, Georgia 30004 USA
1-800-325-7540

BLOCK BUDDY™

ASSEMBLY INSTRUCTIONS

4.

Place the Magnum Controller on the bracket on the left. Place the two pronged mini plug from the harp into the top of the Controller.

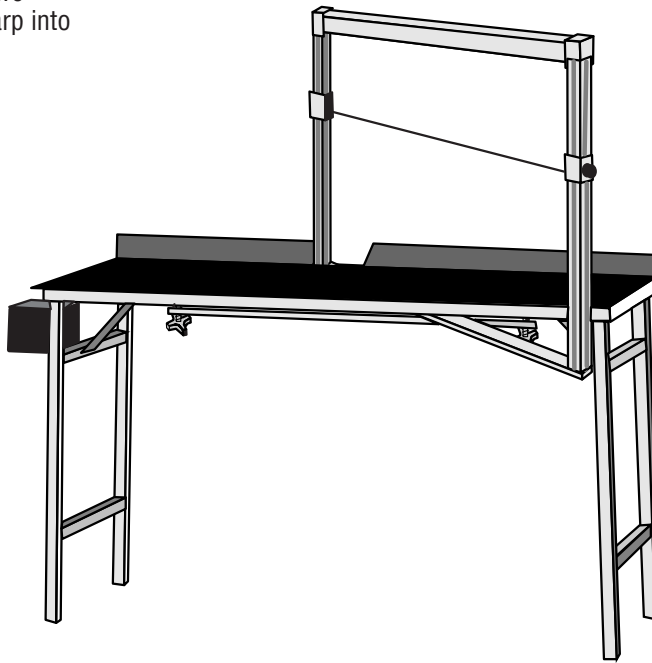

For cutting wire replacement, refer to Step #3 on page 1 of instructions.

Magnum Power Controller – Use nothing longer than a 50 foot 12/3 grounded extension cord. Set the temperature dial on the Magnum to zero (0). Turn on the Magnum and adjust the dial until the Ni-chrome wire turns red. Immediately back off the controller until the wire just begins to turn from red to gray. This is the optimum cutting temperature of the wire. Anything hotter will cause premature wire failure or anything cooler will require too much feed pressure on the wire causing premature failure. If the wire is too hot, the cut may not be as accurate as you would like. A wire that is too hot will melt the foam too quickly at the beginning of the cut and less quickly as the wire cools off resulting in an inaccurate cut.

- Use only 23 gauge NW100 Ni-Chrome wire.
- Do not use this equipment in wet or damp conditions.
- Use only grounded receptacles.

Note: Wire expands when hot. If the spring is too tight the wire may break restricting operation of mechanism. If too loose, the cuts will be sloppy. Readjustment of tension may be necessary from time to time.



DEMAND PRODUCTS, INC.

1055 Nine North Drive
Alpharetta, Georgia 30004 USA
1-800-325-7540

Hot Wire Basics

Hot Wire Basics

Whether you are using Ni-Chrome or Inconel wire, the basics are pretty much the same —

1. To attach the tension spring and wire start on one side and connect the wire with a tight wrap knot to the attachment point. See figure A.
2. Attach the tension spring to the other side and loop the wire through the open end of the spring. Pull the wire tight until the spring is about 2 times its normal length. Then secure the wire with a tight wrap knot. See figure B.
3. Connect the alligator clips to the wire knots on each side. Do not attach the clips to anything other than the wire knot.
4. With the controller set at "0", turn the controller on and slowly dial up the heat control until the wire begins to glow orange. Then quickly turn the controller down until the wire becomes gray. The first stage of gray color is normally the optimum wire temperature for cutting.

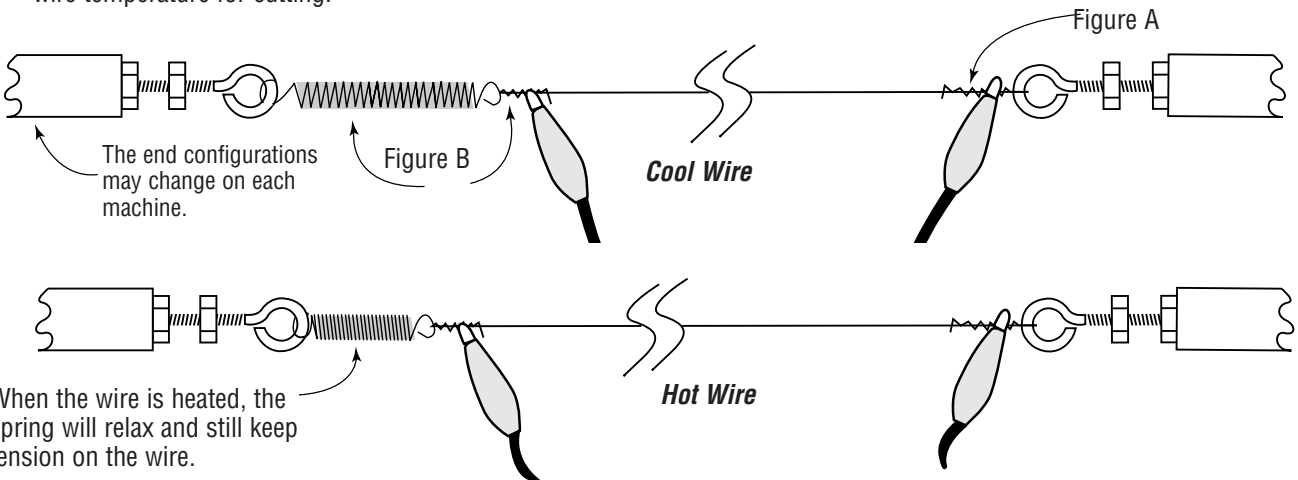

Safety Tips

Note: Wire expands when hot. If the spring is too tight the wire may break restricting operation of mechanism. If too loose, the cut will be sloppy. Readjustment of tension may be necessary from time to time.

Power Controller – Use nothing longer than a 50 foot 12/3 grounded extension cord. Set the temperature dial on the controller to zero (0). Turn on the controller and adjust the dial until the wire glows orange. Immediately back off the controller until the wire just begins to turn from orange to gray. This is the optimum cutting temperature of the wire. Anything hotter will cause premature wire failure or anything cooler will require too much feed pressure on the wire causing premature failure. If the wire is too hot, the cut may not be as accurate as you would like. A wire that is too hot will melt the foam too quickly at the beginning of the cut and less quickly as the wire cools off resulting in an inaccurate cut.

- Use only the recommended wire.
- Do not use this equipment in wet or damp conditions.
- Use only grounded receptacles.



DEMAND PRODUCTS, INC.

1055 Nine North Drive
Alpharetta, Georgia 30004 USA
1-800-325-7540